

Key Plan  
N.T.S.

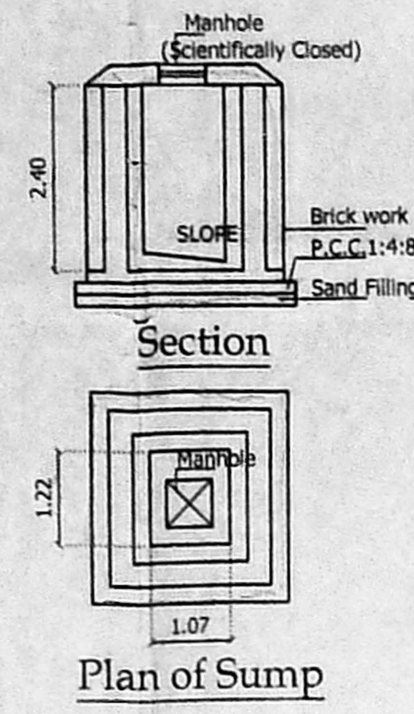

Section  
Plan of Sump

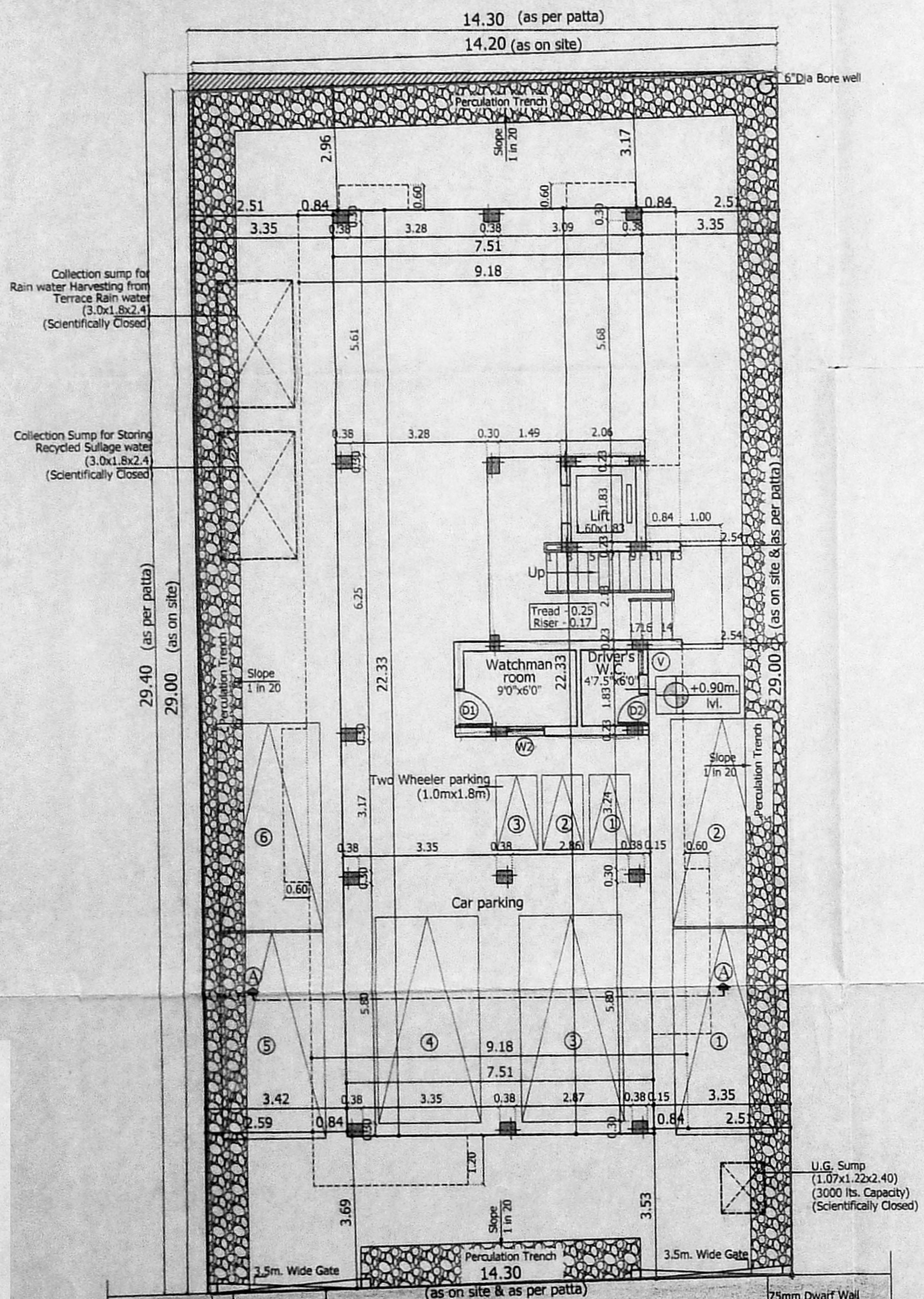

Site/Stilt Floor Plan

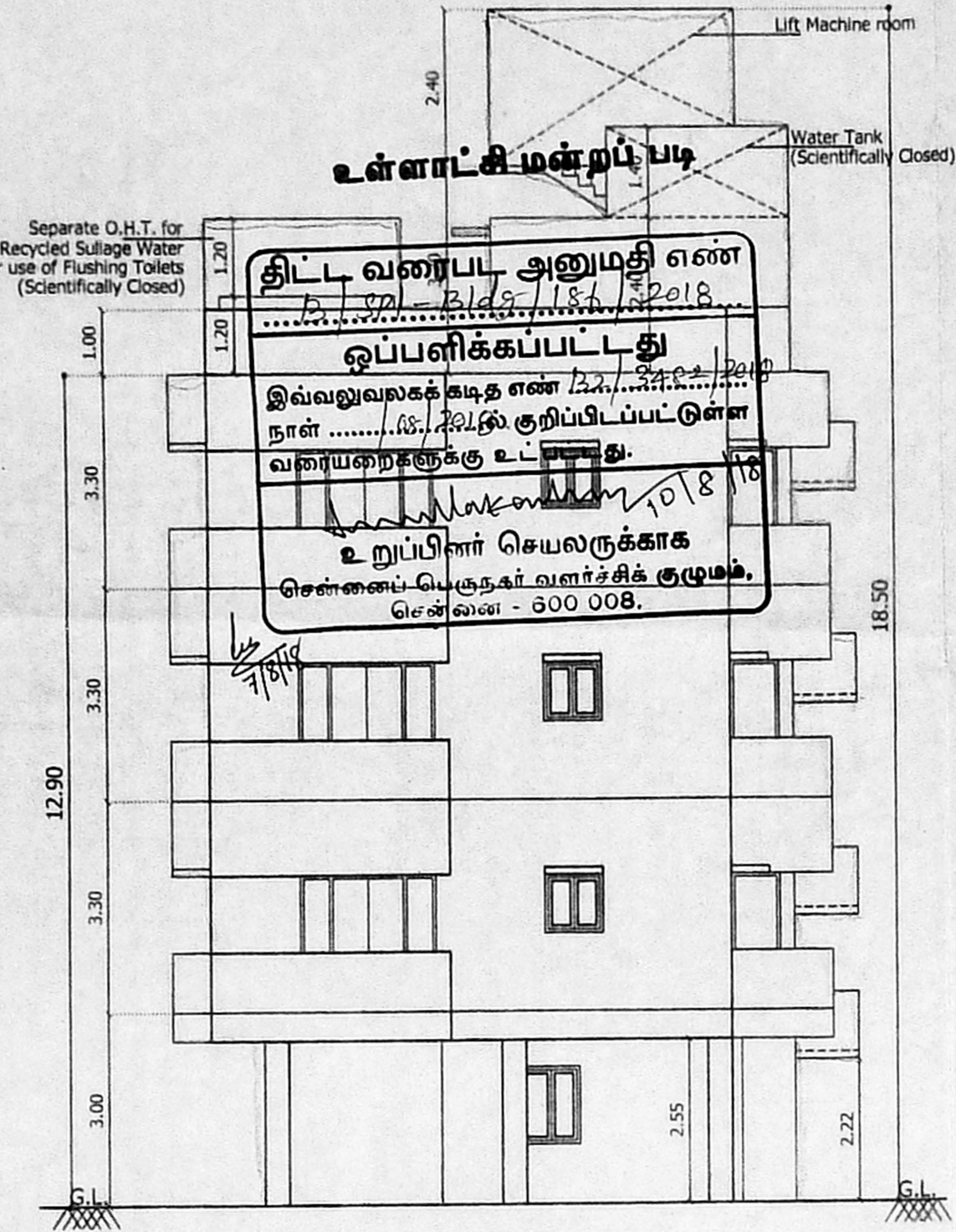

Elevation

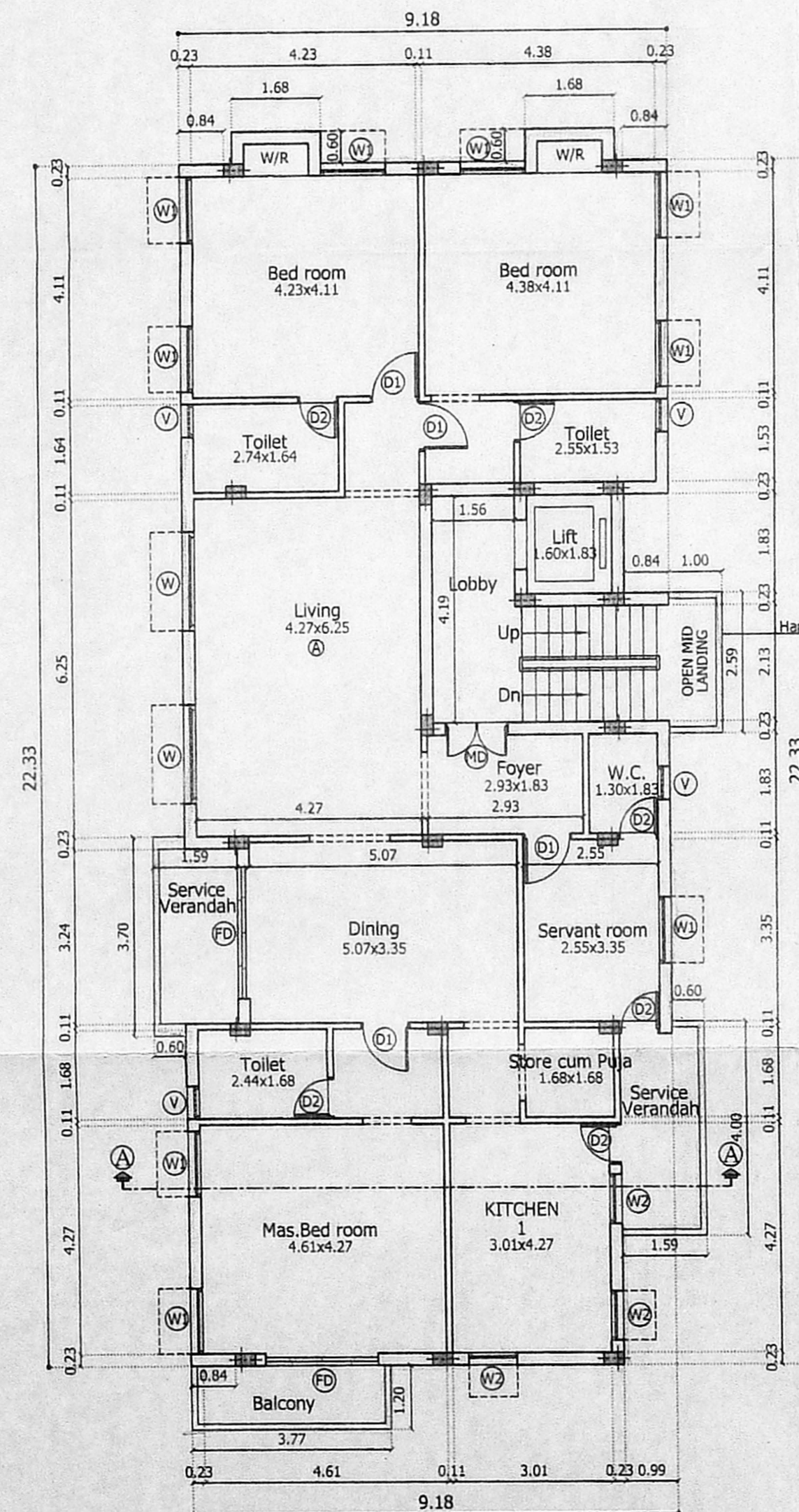

Typical Floor Plan  
(First, Second & Third Floor)

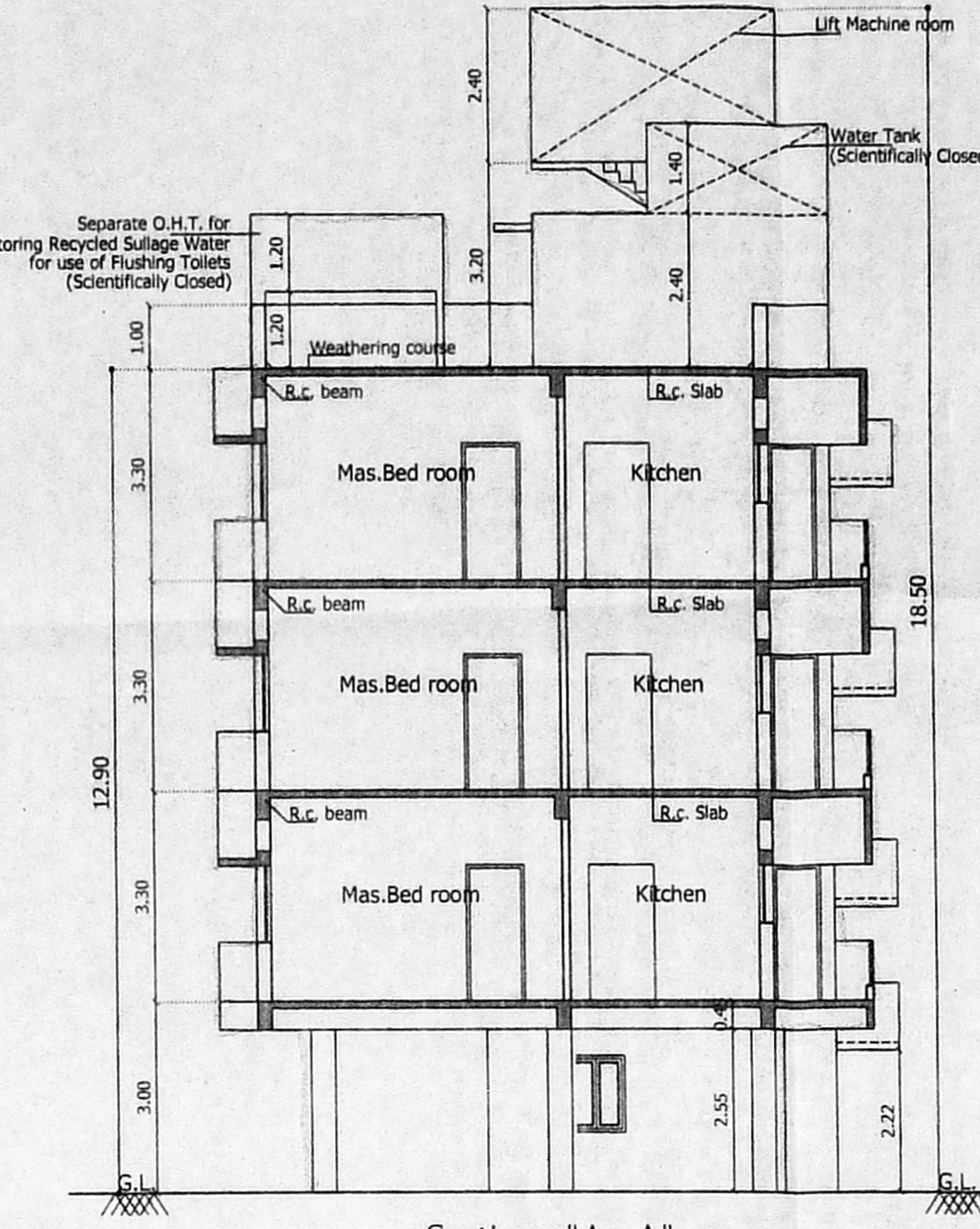

Section - "A - A"

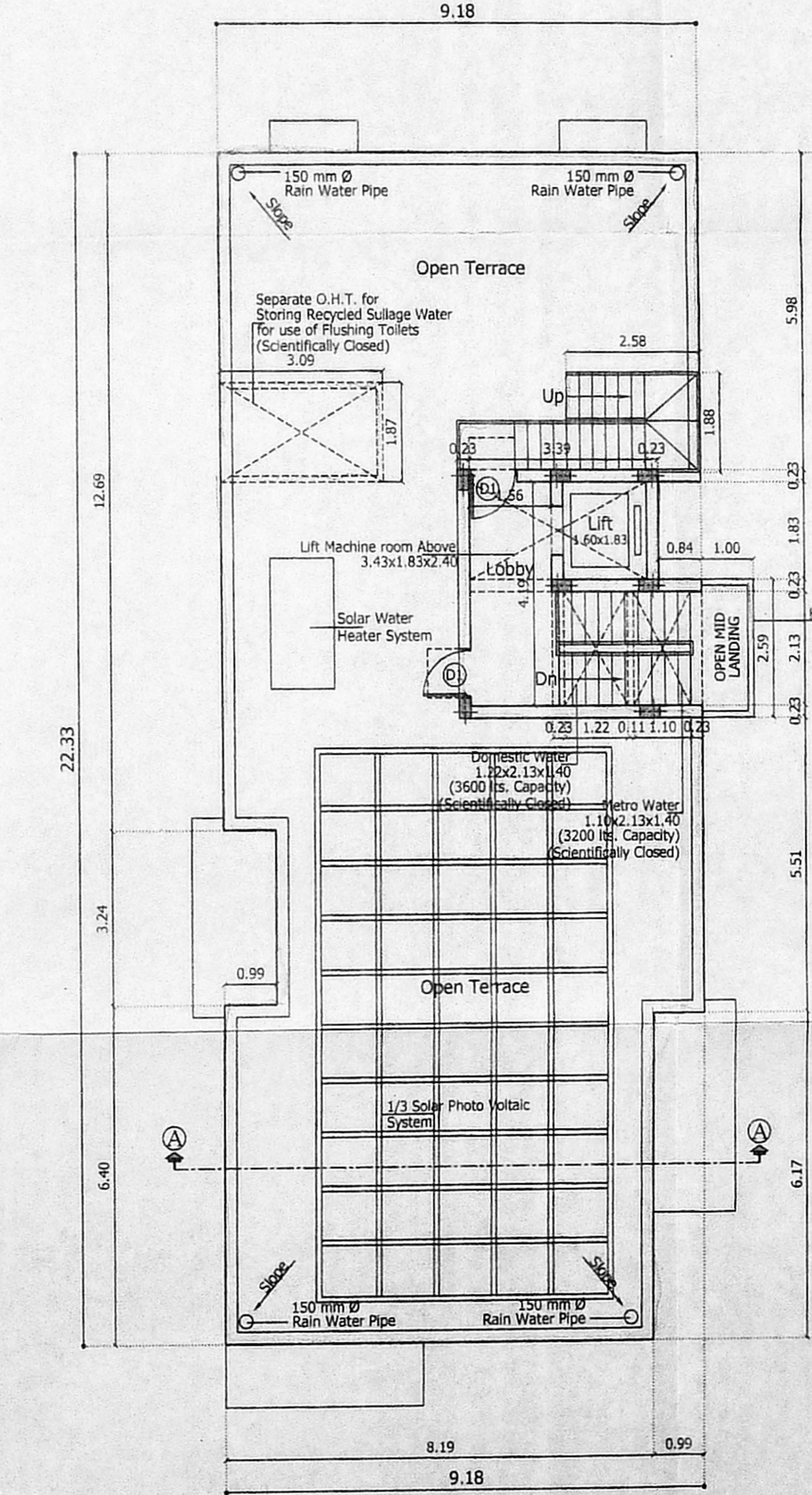

Terrace Floor Plan

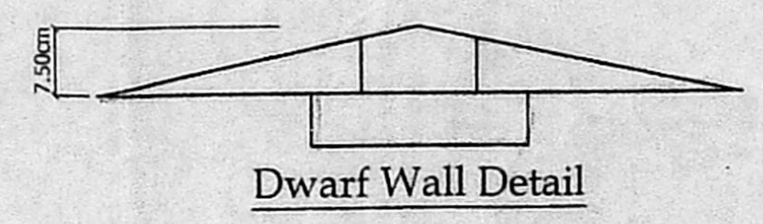

Dwarf Wall Detail

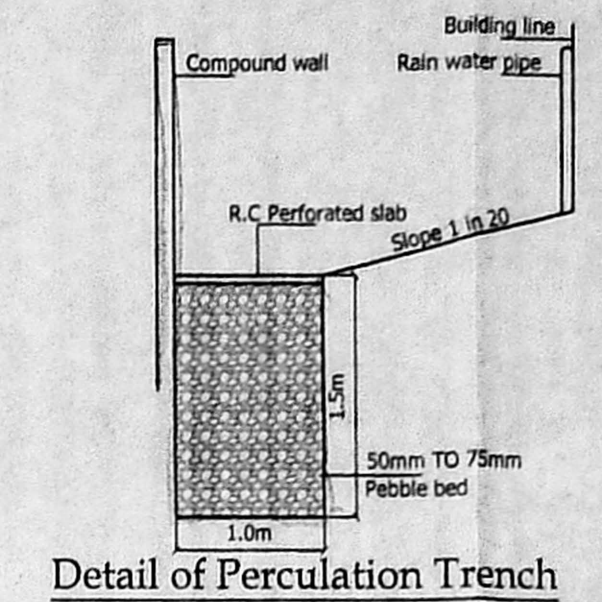

Detail of Percolation Trench

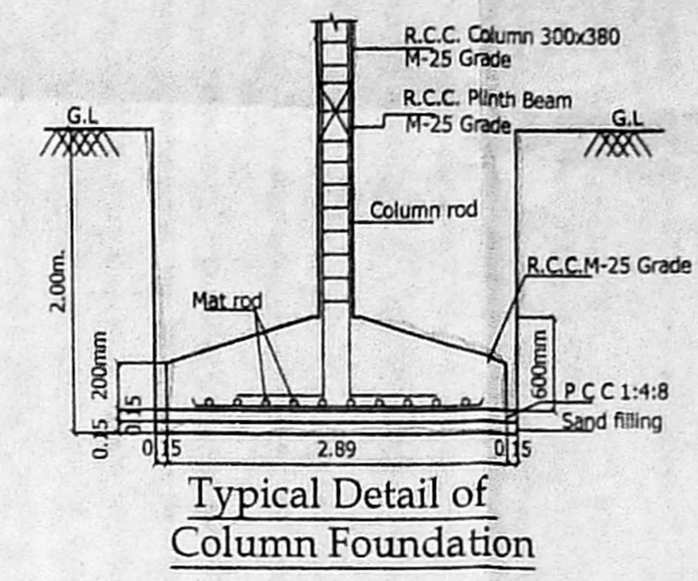

Typical Detail of  
Column Foundation

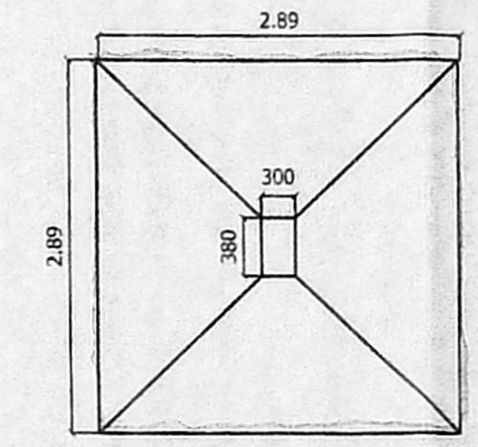

Plan of Column Foundation

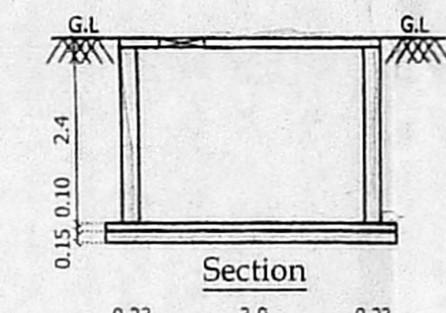

Section

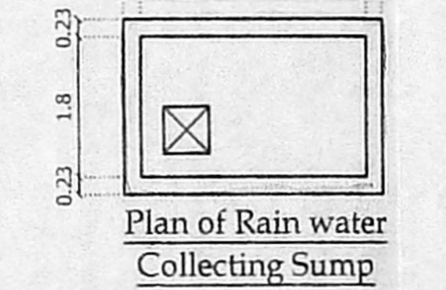

Plan of Rain water  
Collecting Sump

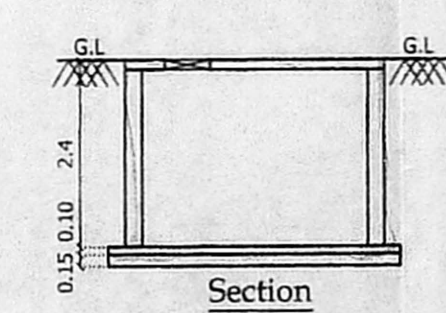

Section

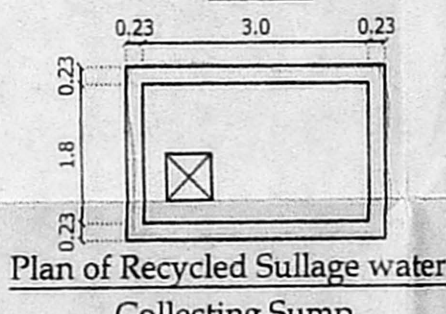

Plan of Recycled Sullage water  
Collecting Sump

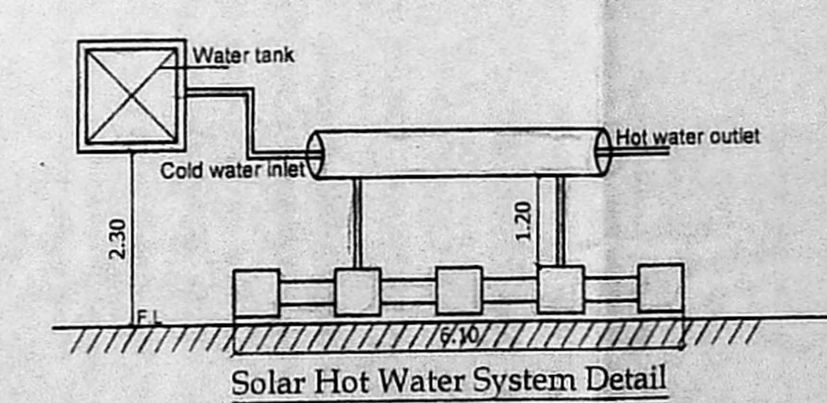

Solar Hot Water System Detail

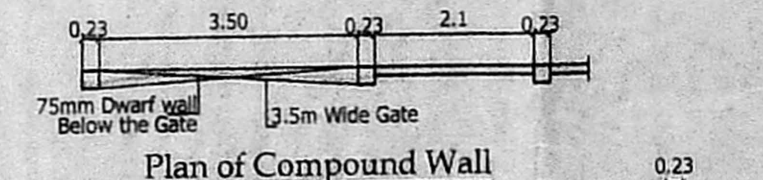

Plan of Compound Wall

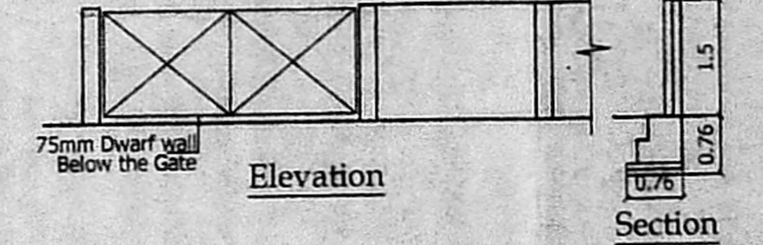

Elevation

SCHEDULE OF JOINERS

S.No	WIDTH	HEIGHT	DESCRIPTION
MD	1.22	2.13	T.W MAIN DOOR
D	1.07	2.13	T.W PANNEL DOOR
D1	0.91	2.13	C.W PANNEL DOOR
D2	0.61	2.13	C.W FLUSH DOOR
FD	2.44	2.13	T.W FRENCH DOOR
W	1.83	1.20	C.W GLAZED WINDOW
W1	1.22	1.20	C.W GLAZED WINDOW
W2	0.91	1.20	C.W GLAZED WINDOW
W3	1.52	0.91	C.W GLAZED WINDOW
WM	0.91	0.91	C.W GLAZED WINDOW
V	0.61	0.61	C.W GLAZED VENTILATOR

- SPECIFICATION
- P.C.C IN M25 GRADE
  - R.C.C IN M25 GRADE
  - 230MM BRICK WORK IN C.M 1:5
  - 115MM BRICK WORK IN C.M 1:5
  - PLASTERING THE CEILING IN C.M 1:3
  - PLASTERING THE WALL IN C.M 1:4
  - WEATHERING COURSE IN BRICK JELLY LIME CONCRETE WITH A COURSE OF FLAT TILES.
  - THE O.H.T IS SCIENTIFICALLY CLOSED
  - THE U.G SUMP IS SCIENTIFICALLY CLOSED
  - ALL W.C.S IN GROUND FLOOR RAISED BY 0.91M FROM G.L

AREA STATEMENT

AS ON SITE	SQ.M
AS ON SITE	414.70
AS PER PATTA	405.50
AS PER DOCUMENT	417.04

Floor	FSI Area	Non FSI Bal. Area
FIRST FLOOR :	202.16	9.75
SECOND FLOOR :	202.16	9.75
THIRD FLOOR :	202.16	9.75
TOTAL BUILTUP AREA	606.48	29.25

F.S.I : 606.48 / 405.50 = 1.496

- LEGEND
- PROPOSED CONSTRUCTION
  - BOUNDARY LINE
  - ROADS

JOB TITLE  
PLAN SHOWING THE PROPOSED CONSTRUCTION OF STILT + 3 FLOORS, RESIDENTIAL BUILDING AT PLOT No. : 24, OLD DOOR No. : 24, NEW DOOR No. : 4, CENOTAPH ROAD 2nd. LANE, TEYNAMPET, CHENNAI - 600 018, COMPRISED IN R. S. No. : 3682/20, BLOCK No. : 73, OF MYLAPORE VILLAGE, GREATER CHENNAI CORPORATION, DIVISION No. : 122, ZONE - 9.

SCALE: 1:100

POWER AGENT :  
For WAVOO REALTY & INVESTMENTS  
Authorised Signatory / Partner's

LICENSED SURVEYOR  
V. SRINIVASAN A.I.A.  
Registered Architect-CA 96, 19755  
Licensed Surveyor-Corporation of Chennai  
BA No. 244  
Firm Arcade, A4271, 17th Street, Anna Nagar,  
Chennai-600 040. Ph: 2678 6529